



Opening the Door to Curtain Walls in AutoCAD® Architecture, Part I

David Driver, President 4D Architects, Ltd.

AB210-3 This class gives you a kit of parts and a set of rules methodology for understanding the styles of Curtain Walls and door/window assemblies. This basic class covers the general terminology and relationships of the parts and will be followed by a more advanced class that covers custom blocks and tips and tricks for these objects.

About the Speaker:

David is a registered architect, and has worked in architectural firms since 1984. He has experience on a range of projects including civic, commercial, and single and multifamily housing. In addition to ongoing production work, David is a consultant on CAD standards and the implementation of Autodesk Building Information Modeling products. An Autodesk Certified Instructor since 1997, David teaches intensive short courses at several Autodesk Authorized Training Centers throughout the U.S. His continuing practice of architecture guarantees his class will target the common tasks and problems encountered in daily office routines.

david@daviddriver.com

Autodesk®



Introduction and Outline

The Curtain Wall object has been around for years in AutoCAD Architecture (ACA) (Ahhh yes, the software formerly known as Architectural Desktop (ADT)). As with most objects in ACA, the more complex the style the more powerful the object. Last Year, I taught this class as one session. In response to various feedback items, I have split this year's class into two parts. Part 1 - this class, a beginner level class, I focus on the basics starting with the Kit of Parts and Set of Rules for working with the curtain wall and door/window Assembly objects. Once the concepts and terminology are covered, we will go on to create a style base curtain wall from scratch., overriding the lower floor to add an entry. This class gives you a kit of parts/set of rules methodology for understanding the styles of Curtain Walls and Door/Window Assemblies. A brief outline for this class is:

20 minutes	Kit of Parts: Frames, Mullions, Infills, Divisions Set of Rules: Grids and Nested Grids	Curtain Walls and Door/Window Assemblies are the third most complex thing in ACA following the display system and schedules. As such they are extremely customizable. They are a very efficient way to get your design intent into 3D, but are frustrating if you do not understand the basic parts and rules that control them.
15 minutes	Curtain Wall Units and Door/Window Assemblies	Brother/Sister objects to the Curtain Wall Style
15 minutes	Dissecting the provided Curtain Wall Styles	A look at how to understand and modify the provided Curtain wall, Curtain wall unit and Door/Window Assembly styles.
20 minutes	Creating a Style Based Curtain Wall from Scratch	Alright, I will not create all of it, but just the crucial elements
10 Minutes	Override Basics	While Part II will cover overrides in depth, a basic discussion of curtain walls is not complete without some idea of the nature of overrides.

Please feel free to ask questions during class. I do have a plan of attack and may ask to defer the question if I think I will cover it later on. Of course if I do not answer a question in class feel free to email me: david@daviddriver.com

Curtain Walls and Door/Window Kit of Parts and Set of Rules

There are three objects in ACA that all use the same interface but behave a bit differently: Curtain Walls, Curtain Wall Units and Door/Window Assemblies. Each of these objects uses the same style dialog boxes to create and manipulate their styles. The differences in these are:

- Curtain Walls stand alone and can have Curtain Wall Units assigned as an infill panel
- Curtain wall units cannot have styles as infills. These are assigned within a curtain wall – to perhaps fill in for an entire floor
- Window assemblies break a hole in the wall and become anchored to the wall like a single door or window.

Regardless, all of these styles have the same interface when it comes time to edit their styles. This interface can be daunting until you realize there is a method to the madness. This chapter introduces you to the KIT of PARTS and SET of RULES that organizes the madness into a system that is understandable. Both the kit of parts and set of rules are accessed from the Design Rules tab of the style.

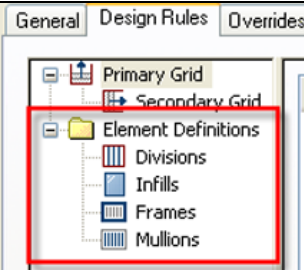
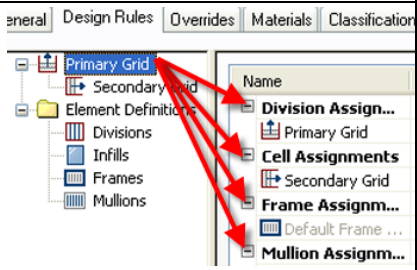
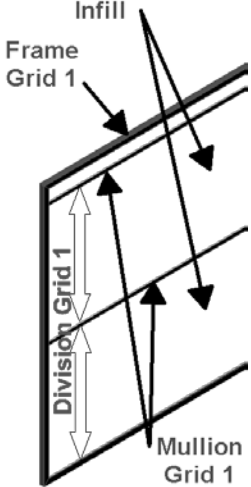
Kit of Parts		Set of Rules
		
<p>The kit of parts are the Element Definitions at the lower part of the tree on the left side of the Design Rules tab of the style</p> <p>Divisions establish the grids (horizontal or vertical elements) within a curtain wall.</p> <p>Infills are what happens within the division spacing</p> <p>Frames wrap around each grid</p> <p>Mullions occur at each grid line</p>		<h3>Set of Rules</h3> <p>Is how each of the elements above are assigned within the style. In the right side of this same Design Rules tab.</p> <p>Grids the organizational structure that holds the definitions of each the kit of parts element definitions</p>

The Kit of Parts

This Section describes each element within the kit of parts. The kit of parts consists of the 4 element definitions shown in the previous table. Each of these elements will get assigned to a grid. Each of the elements governs a separate aspect of the grid.



Kit of Parts: Divisions

Divisions establish how often the grid is chopped up.

The screenshot shows the 'Divisions' dialog box in AutoCAD Architecture. The 'Name' field is 'Horizontal Division'. The 'Orientation' is set to 'Horizontal'. The 'Division Type' dropdown is open, showing options: 'Fixed Cell Dimension', 'Fixed Number of Cells', 'Manual', and 'Baseline/Base Height'. The 'Fixed Cell Dimension' option is selected. The 'Bottom Offset' is '0"'. The 'Top Offset' is '0"'. The 'Cell Dimension' is '13'-0"'. The 'Auto-Adjust Cells' checkbox is checked. The 'Cell Adjustment' dropdown is set to 'Shrink'. The 'Specific Cells' section has three icons. There is a checkbox for 'Maintain at least half of cell dimension' which is unchecked. A 'Convert to Manual Division' button is at the bottom.

Fixed Cell dimension (every thirteen feet)

Fixed number of cells (make it three divisions no matter how high it gets)

Manual (Absolutely make a division 15' above the baseline, 27' above the baseline etc)

Baseline/BaseHeight Controls what happens with stepped baselines and gable shaped roof lines.

AutoAdjust Cells allows you to specify what happens if the dimensions of the grid does not equal an even cell dimension.

More divisions notes:

Cell is a term that is a bit confusing to new users. The division establishes a series of lines. What happens inside these lines is termed the Cell when you are talking about the grid. However what you assign to this area is an infill. All the other terms match 1:1 (a frame element is a frame in the grid etc). I am not sure why this one is different.

Baseline/base height: For more info and a good series of images refer to help topic [Excluding Gables and Steps from a Curtain Wall Grid]

Kit of Parts: Infills

The infill element tells the grid what happens between the divisions. inside the grid (or what is assigned to the cell of a grid)

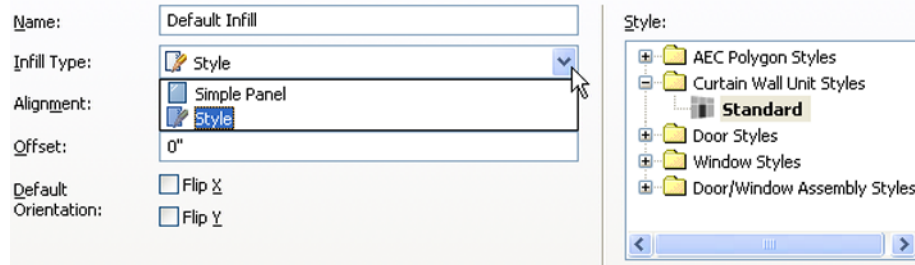

Infills can be either a simple panel or a style definition. A simple panel is just that a solid infill with a specified offset and thickness

Alignment Center front or back is of the panel and will move the specified edge of the panel to the centerline of the curtain wall

Column

Column

Offset is used to push the infill to one edge of the curtain wall or the other.

Important! Remember the native orientation of an ACA object is drawn from left to right in the world UCS. Any Offset X or Offset Y you see in these styles will refer to this orientation regardless of the orientation of the actual curtain wall in the drawing.

More infill notes:

You can get creative with simple panel infills – a stone panel may be an infill that is 8 inches thick, the mortar joint a mullion that is ½ inch x 7.5 inches

You can use a style as an infill – doors and windows – the window or door will fill up the “cell” it is assigned to. When using door and window styles in the infill definition, create a style that sets the frame width to 0 to avoid having a double frame appear in the final product.

Curtain Wall Unit styles cannot have styles assigned as an infill type.

Kit of Parts: Mullions and Frames

Frames are always around the outside of a grid.

A mullion is placed at each grid spacing established by the division.

Mullions and frames basically have the same control.

Width – think of a frame running vertically and you are looking at it from the front. Width will be how wide

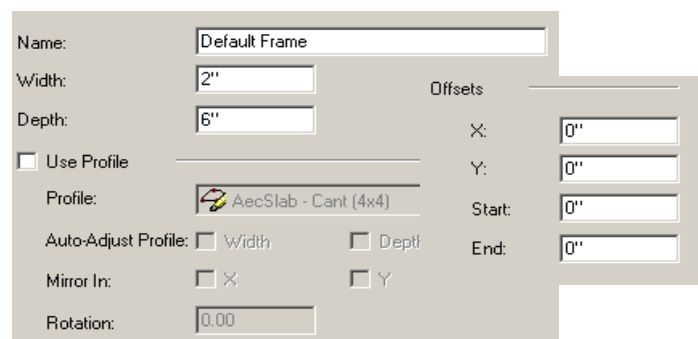



the frame or mullion is. Depth is the thickness in the wall

Offsets: Again, think of a wall drawn from left to right – X offset will shift left and right, Y will shift in the depth of the curtain wall

Use Profile: - any shape you can draw as a closed pline, you can make into a profile and use as a frame or a mullion.

OK, that is the kit of parts...where it gets complex is when you have a grid nested inside another grid, which brings us to...

The Set of Rules!

The set of rules for the Design Rules tab is the same regardless of what object style you are working with Curtain Walls, Curtain Wall Unit styles, or Door/Window Assembly styles.

There are two main areas of the Design Rules tab that establish the set of rules. These are the Grid Tree on the upper left and the Name/Element/Type/Used In area on the upper right.

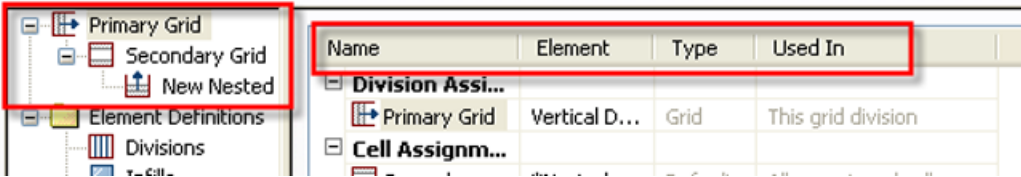

I am going to discuss the Name/Element/Type/Used In table first to avoid talking about nested grids until later in this section.

Name/Element/Type/Used In Table

The Name/Element/Type/Used In table is where you assign the element definitions.

Name	Element	Type	Type	Used In
<ul style="list-style-type: none"> [-] Division Assign... [-] Secondary Grid [-] Cell Assignments <ul style="list-style-type: none"> [+] New Nested Grid [+] Top Cell [-] Frame Assignm... <ul style="list-style-type: none"> [+] Default Frame ... [+] Top and Bottom [-] Mullion Assignm... <ul style="list-style-type: none"> [+] Default Mullion ... 	<ul style="list-style-type: none"> Manual Division *Nested Grid* Top Infill Default Boundary Bottom Top Frame Horizontal Bands 	<ul style="list-style-type: none"> Grid Default Location Index Location Default 	<ul style="list-style-type: none"> Grid Default Location Location Default Index 	<ul style="list-style-type: none"> This grid division All unassigned cells Top Top Top, Bottom All unassigned mullions 1, 4
<p>The first column "Name" tells you What Part (element) you are working with.</p>	<p>The second column shows what element definition is assigned to this grid.</p>	<p>The third column "Type" is Where you want the element placed in relationship to the grid.</p>	<p>The fourth column just defines the parameter set in the type column. For index locations, enter integer(s). For location types this is a pick box.</p>	

Typical to most ACA dialog boxes, although the pull down arrows or other selection choices do not show normally when looking at the dialog box. You must pick in the element area, type location area or Used In area to be able to select by drop down or pick box.

Type column has two choices for the Cell or Mullion component; Location or Index

Location is just a choice either of Start Middle End or Top Middle Bottom depending on the orientation of the division assigned to the grid

Index number takes one or more integers and places (proceeding from start to end, on bay numbers 1,3,5)

Grid Tree and Nested Grids

	<p>There are some things you will notice when working with the Name/Element/Type/Used In table. The first thing you will probably notice is that you can add infills, frames and mullions but not divisions.</p> <p>Each division must have its own grid.</p>
	<p>The example at the upper left is a single grid curtain wall definition. Its Design Rules look like this.</p> <p>The <i>horizontal divisions</i> is defined as repeating every 13' up.</p>
	<p>Instead of using an infill definition you can assign a nested grid to the cell assignment</p>
	<p>After you have made this nested grid assignment you will then see the secondary or nested grid at the upper left in the grid tree.</p> <p>Notice in this image the Primary grid is selected. This is where the nested grid is assigned</p>
	<p>This nested grid gets its own Division Assignment, in this case a vertical division that is set to divide every 5'</p> <p>Notice in this image the new nested grid is selected. Each nested grid gets its own division assignment</p>

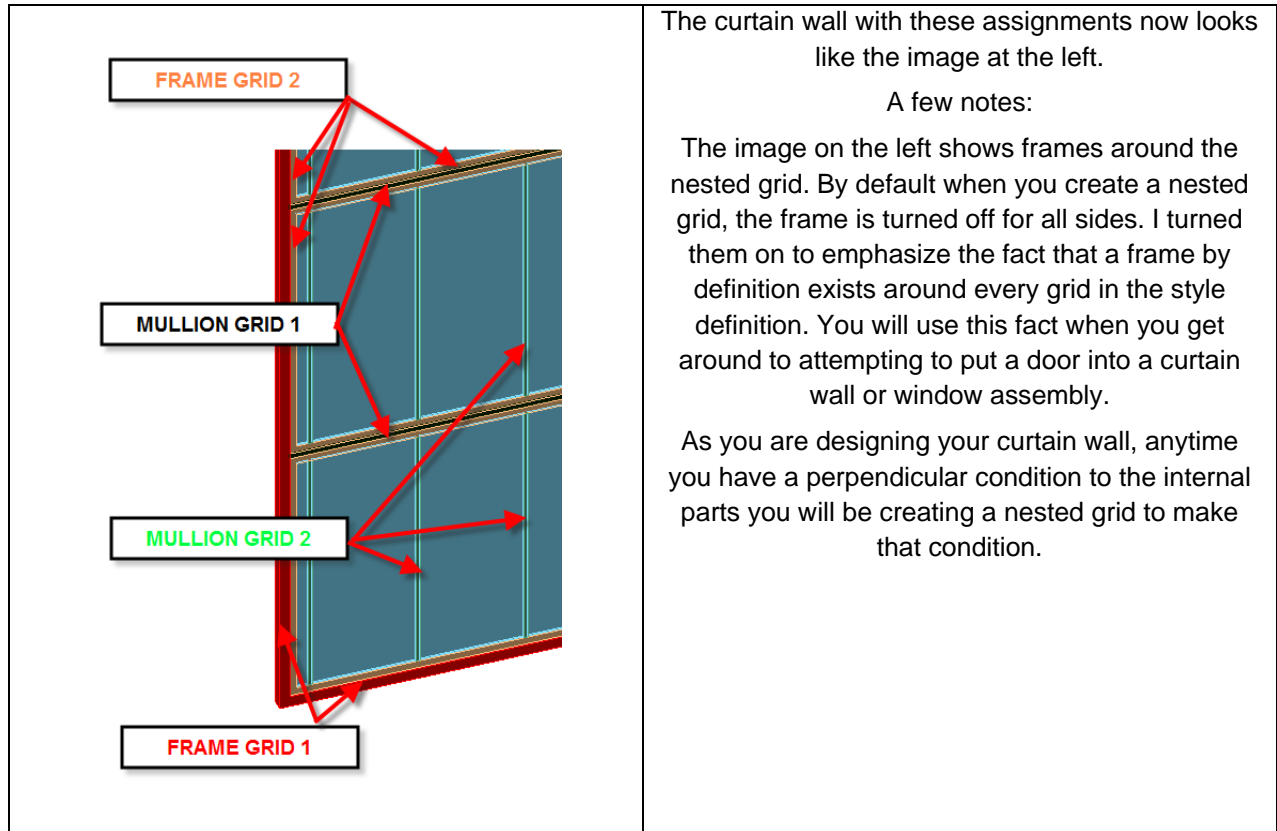

The curtain wall with these assignments now looks like the image at the left.

A few notes:

The image on the left shows frames around the nested grid. By default when you create a nested grid, the frame is turned off for all sides. I turned them on to emphasize the fact that a frame by definition exists around every grid in the style definition. You will use this fact when you get around to attempting to put a door into a curtain wall or window assembly.

As you are designing your curtain wall, anytime you have a perpendicular condition to the internal parts you will be creating a nested grid to make that condition.

That's it for the kit of parts and set of rules for style based Curtain Walls, Curtain Wall Unit styles, or Door/Window Assembly styles. If you understand this systems way of thinking about these styles you can come up with some very complex styles.

For those of you reading this in the office, on your own, experiment with the styles provided in the Content Browsers Design Tool Catalog. Can you figure out how to modify the spacing of the Square Grid 5' x 5' style to make it 5' window widths but horizontal divisions at 3', 8', 12' 15', 20' ect?



Success with Curtain Walls or Door/Window Assemblies:

1) Plan your attack

Sketch out the curtain wall

One color for each level grid you will need

2) Create the kit of parts in your style based on your sketch

Make all the division definitions you will need

Create all the infill definitions

Create or modify the frames

Create or modify the mullions

3) Start with the primary grid

Assign the most common division you created in step 2 to this grid

Create as many cells as you need to assign to this primary level of the grid

(each different floor that has a different condition may need its own cell)

Create nested grids in the cell assignments

Verify your frame assignments (does the bottom frame go on at this level (primary grid)? Or will it need to be assigned to one of the nested grids

Verify the mullion (size, definition etc)

4) OK back to the drawing and SAVE!

Curtain walls are time intensive to create, but once created are much easier to modify and do design studies with. The last thing you want is to spend an hour creating a beautiful curtain wall definition and then lock up and lose your work. Save Early, Save often

5) Repeat step 3 with ONE of your nested grids.

6) OK back to the drawing, add a curtain wall of the style you are developing, look at it in 3D view. Is it what you expected? If not, fix it here before you go on.

It is much too easy to dead end yourself while create a curtain wall. "OK" back to the drawing window frequently to check that the changes you have made match the intent of your initial sketch. The second most frustrating thing (the first is having the computer crash before you have saved your masterpiece) about complex curtain walls is spending 20 minutes in the style dialog box working with 5 levels of nested grids only to find out you made a mistake on the second level of the nested grids and have to go back and recreate the entire branch of the grid tree.

The outside of Frames are by default justified to the exterior extents of the grid

Mullions are by default justified to the center of the division

Be judicious with the use of the Default assignments. Especially within the cell assignments. You cannot delete them. Instead, just add the number of cells you will use and assign the infills and nested grids. If the default assignment never ends up being used so much the better

Personal preference is to keep my divisions so that they can be applied always by location (start, mid, end). Usually if I start thinking about using index types, I go back to the drawing board and redesign my grids. The exercise included here does use indexes, only because I designed it as an educational tool.



Exercise: Creating a Curtain Wall Style from Scratch

This exercise will lead you through creating a curtain wall from scratch. If you are following along in your office, I make the following assumptions.

- You can create a new style on your own
- You can add one of these objects in the drawing.
- You can access the style definition and open it up for editing either through style manager or by adding an object of that style and accessing the style with the right click functions.
- You have read the previous sections and have some idea of the concepts and terminology of Curtain wall styles
- You have a basic understanding of the display system used by AutoCAD Architecture
- You know where to find the materials and can apply them to a style's components

While these may appear like simple assumptions, it will save me many lines of exercise steps. This exercise will create a curtain wall that looks like this:

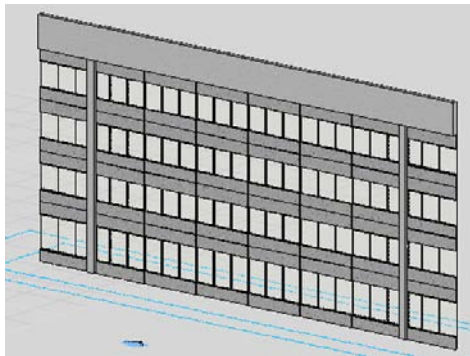

This is a stucco panel system within a curtain wall system. The glazing on the ends is butt joint, while the interior section glazing is exposed mullions. The two 24" square columns are to stay 15 feet from each end regardless of the length of the curtain wall. The top portion is an 8' tall parapet that extends 18 inches from the centerline of the curtain wall out. The system should grow or shrink floors easily.







A note: When I am creating one of these types of styles or a door/window assembly style I plan the style out before I create it. I am mixing the two processes in this exercise







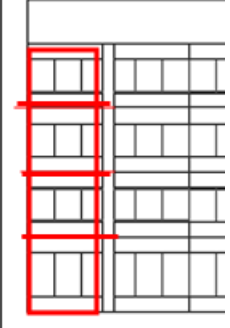



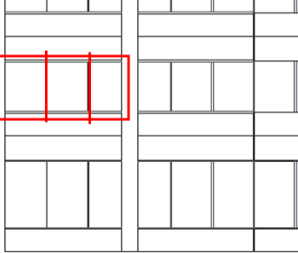

Create a new curtain wall style and add it to a drawing.

Right click and edit this style

Plan and create Divisions: there are as many ways to create the divisions to end up with the same curtain wall as there are designers. I will try to comment on why I chose these here. The odd names in *italics* are the names of the divisions in the final style. You do not need to do anything yet, just scan through the sketches. By planning out the curtain wall ahead of time you will save yourself time in the style manager.

Planning part	Some rationalization	Division settings	Division settings
---------------	----------------------	-------------------	-------------------

	<p>MainOverall</p> <p>The first division sets the parapet apart from the rest of the building. This will be a manual division</p>	<p>Name: <input type="text" value="MainOverall"/></p> <p>Orientation: </p> <p>Division Type: <input type="radio"/> Manual</p>	<p>Bottom Offset: <input type="text" value="0"/></p> <p>Top Offset: <input type="text" value="0"/></p> <table border="1"> <thead> <tr> <th>Gridline</th> <th>Offset</th> <th>From</th> </tr> </thead> <tbody> <tr> <td>1</td> <td>8'-0"</td> <td>Grid Top</td> </tr> </tbody> </table>	Gridline	Offset	From	1	8'-0"	Grid Top									
Gridline	Offset	From																
1	8'-0"	Grid Top																
	<p>MainColumns</p> <p>This second division will create the columns. The intent is to have 2'x2' columns that remain 15' center to each end. This will also be a manual division</p> <p>Now look within these rectangles to find commonality</p>	<p>Name: <input type="text" value="MainColumns"/></p> <p>Orientation: </p> <p>Division Type: <input type="radio"/> Manual</p>	<p>Start Offset: <input type="text" value="0"/></p> <p>End Offset: <input type="text" value="0"/></p> <table border="1"> <thead> <tr> <th>Gridline</th> <th>Offset</th> <th>From</th> </tr> </thead> <tbody> <tr> <td>1</td> <td>14'-0"</td> <td>Grid Start</td> </tr> <tr> <td>2</td> <td>16'-0"</td> <td>Grid Start</td> </tr> <tr> <td>3</td> <td>16'-0"</td> <td>Grid End</td> </tr> <tr> <td>4</td> <td>14'-0"</td> <td>Grid End</td> </tr> </tbody> </table>	Gridline	Offset	From	1	14'-0"	Grid Start	2	16'-0"	Grid Start	3	16'-0"	Grid End	4	14'-0"	Grid End
Gridline	Offset	From																
1	14'-0"	Grid Start																
2	16'-0"	Grid Start																
3	16'-0"	Grid End																
4	14'-0"	Grid End																
	<p>FloorToFloor</p> <p>The next division establishes the floor line. You could create this without this division, but I will use it here and just slide a stucco joint in at this division. If left this step out then this vertical slicing would all be manual. This way I have a separate division that I can use to control floor to floor height. This division will be used for all three sections left, middle and right</p>	<p>Name: <input type="text" value="FloorToFloor"/></p> <p>Orientation: </p> <p>Division Type: <input checked="" type="radio"/> Fixed Cell Dimension</p>	<p>Bottom Offset: <input type="text" value="0"/></p> <p>Top Offset: <input type="text" value="0"/></p> <p>Cell Dimension: <input type="text" value="12'-0"/></p> <p><input checked="" type="checkbox"/> Auto-Adjust Cells</p> <p>Cell Adjustment: <input type="text" value="Grow"/></p> <p>Specific Cells: </p>															

	<p>OneFloorDivision</p> <p>Again, taking one more step into the grid previously described, this division will also be applied in many places.</p>	<p>Name: <input type="text" value="OneFloorDivision"/></p> <p>Orientation: </p> <p>Division Type: </p>	<p>Bottom Offset: <input type="text" value="0"/></p> <p>Top Offset: <input type="text" value="0"/></p> <table border="1"> <thead> <tr> <th>Gridline</th> <th>Offset</th> <th>From</th> </tr> </thead> <tbody> <tr> <td>1</td> <td>2'-10"</td> <td>Grid Bottom</td> </tr> <tr> <td>2</td> <td>3'-0"</td> <td>Grid Top</td> </tr> </tbody> </table>	Gridline	Offset	From	1	2'-10"	Grid Bottom	2	3'-0"	Grid Top
Gridline	Offset	From										
1	2'-10"	Grid Bottom										
2	3'-0"	Grid Top										
	<p>WindLeft</p> <p>This will be a fixed distance type of division set at 5'.</p> <p>The auto adjust will be set to shrink right side. This means that I will have to create another one of these for the other side of the column that auto adjusts the left side.</p>	<p>Name: <input type="text" value="WindLeft"/></p> <p>Orientation: </p> <p>Division Type: </p>	<p>Start Offset: <input type="text" value="0"/></p> <p>End Offset: <input type="text" value="0"/></p> <p>Cell Dimension: <input type="text" value="5'-0"/></p> <p><input checked="" type="checkbox"/> Auto-Adjust Cells</p> <p>Cell Adjustment: <input type="text" value="Shrink"/></p> <p>Specific Cells: </p>									
	<p>WindRight</p>	<p>Name: <input type="text" value="WindRight"/></p> <p>Orientation: </p> <p>Division Type: </p>	<p>Start Offset: <input type="text" value="0"/></p> <p>End Offset: <input type="text" value="0"/></p> <p>Cell Dimension: <input type="text" value="5'-0"/></p> <p><input checked="" type="checkbox"/> Auto-Adjust Cells</p> <p>Cell Adjustment: <input type="text" value="Shrink"/></p> <p>Specific Cells: </p>									
	<p>Center15foot</p> <p>This will be a separate fixed distance division set at 15' each.</p> <p>In this instance auto-adjust will be set to shrink both sides.</p>	<p>Name: <input type="text" value="Center15foot"/></p> <p>Orientation: </p> <p>Division Type: </p>	<p>Start Offset: <input type="text" value="0"/></p> <p>End Offset: <input type="text" value="0"/></p> <p>Cell Dimension: <input type="text" value="15'-0"/></p> <p><input checked="" type="checkbox"/> Auto-Adjust Cells</p> <p>Cell Adjustment: <input type="text" value="Shrink"/></p> <p>Specific Cells: </p> <p><input checked="" type="checkbox"/> Maintain at least half of cell dimension</p>									

	<p><i>WindCenter</i></p> <p>is just a fixed distance 5' division that I will use in the center area away from the columns that adjusts both ends though it should never need to</p>	<p>Name: WindCenter</p> <p>Orientation: </p> <p>Division Type: Fixed Cell Dimension</p>	<p>Start Offset: 0"</p> <p>End Offset: 0"</p> <p>Cell Dimension: 5'-0"</p> <p><input checked="" type="checkbox"/> Auto-Adjust Cells</p> <p>Cell Adjustment: Shrink</p> <p>Specific Cells: </p>
--	---	---	--

At this point, ok back to the drawing and save it just like it is. The definitions have not been applied, but I would hate for you to get a telephone call and hit the cancel or close button at this point.

Plan and create the infills:

Planning: You will need 4 infills, one for the column which is 24" deep, one for the parapet 18" deep, one for the stucco infill at 6.5" another for the window at 1/2"

Create the following infill element definitions in the style

<p>Name: Column</p> <p>Infill Type: Simple Panel</p> <p>Alignment: Center</p> <p>Offset: 0"</p>	<p>Panel Thickness = 2'-0"</p>
<p>Name: parapet</p> <p>Infill Type: Simple Panel</p> <p>Alignment: Back</p> <p>Offset: 3"</p>	<p>Panel thickness = 1'-6"</p>
<p>Name: StuccoInfill</p> <p>Infill Type: Simple Panel</p> <p>Alignment: Center</p> <p>Offset: -1"</p>	<p>Panel thickness = 6 1/2"</p>
<p>Name: Window</p> <p>Infill Type: Simple Panel</p> <p>Alignment: Center</p> <p>Offset: 0"</p>	<p>Panel thickness = 1/2"</p>



Plan and create mullions:

Because I know that I have just designed a grid line through my stucco panel at the floor height (see FloorToFloor division in previous section), I will need a stucco joint at perhaps 5" x 1/2" or stucco reveal at 5" x 2". I will also need a butt joint for each of the ends of the curtain wall.

<p>Name: <input type="text" value="mullion"/></p> <p>Width: <input type="text" value="2"/></p> <p>Depth: <input type="text" value="6"/></p>	No offsets or profiles
<p>Name: <input type="text" value="ButtGlaze"/></p> <p>Width: <input type="text" value="1/2"/></p> <p>Depth: <input type="text" value="1/2"/></p>	No offsets or profiles
<p>Name: <input type="text" value="StuccoJoint"/></p> <p>Width: <input type="text" value="1/2"/></p> <p>Depth: <input type="text" value="5"/></p>	No offsets or profiles
<p>Name: <input type="text" value="StuccoReveal"/></p> <p>Width: <input type="text" value="1"/></p> <p>Depth: <input type="text" value="5"/></p>	No offsets or profiles

Save your drawing and return to the style dialog box



Exercise Curtain Wall Continued: Set of Rules

Now that you have created all the parts for the style you are ready to put them together with the grids. I am just providing the screen caps of each grid settings.

Tip: you may want to assign materials to the components before starting to create the grids. Often I will take some very dissimilar materials and assign them to the different parts (i.e. stucco joint black something, stucco reveal a red material). While this will not be the final colors it makes visually identifying errors in the grid definitions much easier.

Tip: When I am creating grids I try not to use the default cell assignment or mullion assignment as these are unforgiving as they cannot be deleted. I will assign a very bright ugly material to the default infill and mullion so they scream at me if I inadvertently use them

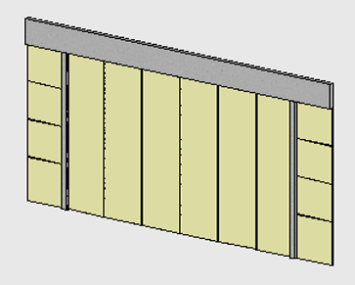
<table border="1"> <thead> <tr> <th>Name</th> <th>Element</th> <th>Type</th> <th>Used In</th> </tr> </thead> <tbody> <tr> <td colspan="4">Division Assignment</td> </tr> <tr> <td>Primary Grid</td> <td>MainOverall</td> <td>Grid</td> <td>This grid division</td> </tr> <tr> <td colspan="4">Cell Assignments</td> </tr> <tr> <td>Default Cell Assig...</td> <td>Default Infill</td> <td>Default</td> <td>All unassigned cells</td> </tr> <tr> <td>New Cell Assignment parapet</td> <td>parapet</td> <td>Location</td> <td>Top</td> </tr> <tr> <td>New Nested Grid</td> <td>*Nested Grid*</td> <td>Location</td> <td>Bottom</td> </tr> <tr> <td colspan="4">Frame Assignments</td> </tr> <tr> <td>Default Frame Ass...</td> <td>Default Frame</td> <td>Location</td> <td>*NONE*</td> </tr> <tr> <td colspan="4">Mullion Assignments</td> </tr> <tr> <td>Default Mullion As...</td> <td>StuccoReveal</td> <td>Default</td> <td>All unassigned mullion</td> </tr> </tbody> </table>	Name	Element	Type	Used In	Division Assignment				Primary Grid	MainOverall	Grid	This grid division	Cell Assignments				Default Cell Assig...	Default Infill	Default	All unassigned cells	New Cell Assignment parapet	parapet	Location	Top	New Nested Grid	*Nested Grid*	Location	Bottom	Frame Assignments				Default Frame Ass...	Default Frame	Location	*NONE*	Mullion Assignments				Default Mullion As...	StuccoReveal	Default	All unassigned mullion	<p>For the primary grid you will need to add a cell assignment and change one of them to a nested grid.</p> <p>Assign parapet infill to the other</p> <p>Turn off all the frames</p> <p>Rename the new nested grid to BreakColumnsOut.</p>												
Name	Element	Type	Used In																																																						
Division Assignment																																																									
Primary Grid	MainOverall	Grid	This grid division																																																						
Cell Assignments																																																									
Default Cell Assig...	Default Infill	Default	All unassigned cells																																																						
New Cell Assignment parapet	parapet	Location	Top																																																						
New Nested Grid	*Nested Grid*	Location	Bottom																																																						
Frame Assignments																																																									
Default Frame Ass...	Default Frame	Location	*NONE*																																																						
Mullion Assignments																																																									
Default Mullion As...	StuccoReveal	Default	All unassigned mullion																																																						
<table border="1"> <thead> <tr> <th>Name</th> <th>Element</th> <th>Type</th> <th>Used In</th> </tr> </thead> <tbody> <tr> <td colspan="4">Division Assignment</td> </tr> <tr> <td>BreakColumnsOut</td> <td>MainColumns</td> <td>Grid</td> <td>This grid</td> </tr> <tr> <td colspan="4">Cell Assignments</td> </tr> <tr> <td>Default Cell Assig...</td> <td>Default Infill</td> <td>Default</td> <td>All unassi</td> </tr> <tr> <td>Left Column</td> <td>Column</td> <td>Index</td> <td>2</td> </tr> <tr> <td>LeftSide</td> <td>*Nested Grid*</td> <td>Location</td> <td>Start</td> </tr> <tr> <td>middle section</td> <td>*Nested Grid*</td> <td>Location</td> <td>Middle</td> </tr> <tr> <td>Right Column</td> <td>Column</td> <td>Index</td> <td>4</td> </tr> <tr> <td>rightSide</td> <td>*Nested Grid*</td> <td>Location</td> <td>End</td> </tr> <tr> <td colspan="4">Frame Assignments</td> </tr> <tr> <td>Default Frame Ass...</td> <td>Default Frame</td> <td>Location</td> <td>*NONE*</td> </tr> <tr> <td colspan="4">Mullion Assignments</td> </tr> <tr> <td>Default Mullion As...</td> <td>mullion</td> <td>Default</td> <td>All unassi</td> </tr> </tbody> </table>	Name	Element	Type	Used In	Division Assignment				BreakColumnsOut	MainColumns	Grid	This grid	Cell Assignments				Default Cell Assig...	Default Infill	Default	All unassi	Left Column	Column	Index	2	LeftSide	*Nested Grid*	Location	Start	middle section	*Nested Grid*	Location	Middle	Right Column	Column	Index	4	rightSide	*Nested Grid*	Location	End	Frame Assignments				Default Frame Ass...	Default Frame	Location	*NONE*	Mullion Assignments				Default Mullion As...	mullion	Default	All unassi	<p>You will add 5 cells here</p> <p>Set the proper elements and rename the cell assignments as shown</p>
Name	Element	Type	Used In																																																						
Division Assignment																																																									
BreakColumnsOut	MainColumns	Grid	This grid																																																						
Cell Assignments																																																									
Default Cell Assig...	Default Infill	Default	All unassi																																																						
Left Column	Column	Index	2																																																						
LeftSide	*Nested Grid*	Location	Start																																																						
middle section	*Nested Grid*	Location	Middle																																																						
Right Column	Column	Index	4																																																						
rightSide	*Nested Grid*	Location	End																																																						
Frame Assignments																																																									
Default Frame Ass...	Default Frame	Location	*NONE*																																																						
Mullion Assignments																																																									
Default Mullion As...	mullion	Default	All unassi																																																						
	<p>Your curtain wall should look something like this. The sides may be a bit different but the parapet was established with the first level grid and the columns with the second.</p>																																																								

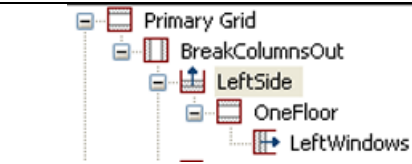

This next section takes you through completing the left side of the curtain wall

You did draw your curtain wall from left to right correct?

On the third level, LeftSide Grid make the settings as shown here

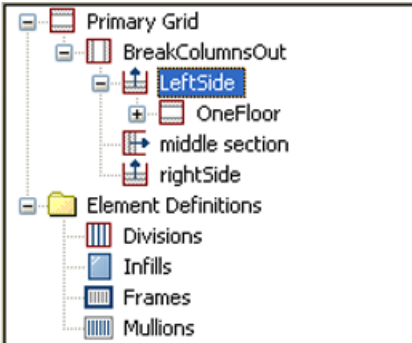

Name	Element	Type	Used In
Division Assignment			
LeftSide	FloorToFloor	Grid	This grid
Cell Assignments			
OneFloor	*Nested Grid*	Default	All unassigned
Frame Assignments			
Default Frame Ass...	Default Frame	Location	*NONE
Mullion Assignments			
Default Mullion As...	StuccoJoint	Default	All unassigned

At the fourth level these settings

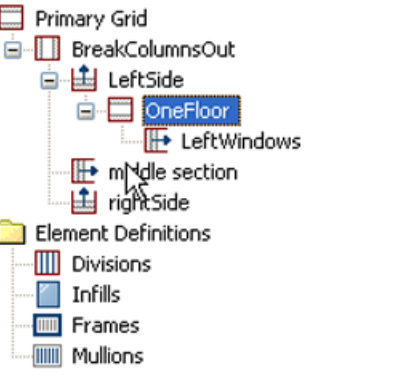

Name	Element	Type	Used In
Division Assignment			
OneFloor	OneFloorDivision	Grid	This grid divisor
Cell Assignments			
Default Cell Assig...	Default Infill	Default	All unassigned c
LeftWindows	*Nested Grid*	Location	Middle
New Cell Assignment	StuccoInfill	Location	Bottom, Top
Frame Assignments			
Default Frame Ass...	Default Frame	Location	*NONE*
Mullion Assignments			
Default Mullion As...	mullion	Default	All unassigned r

Finally! At the fifth level:

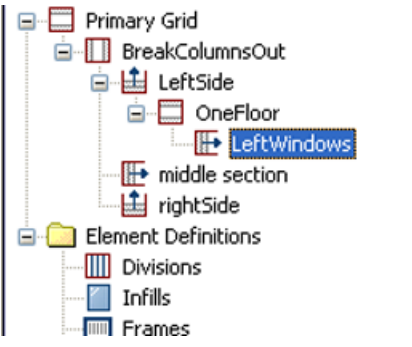

Name	Element	Type	Used In
Division Assignment			
LeftWindows	WindLeft	Grid	This grid
Cell Assignments			
Default Cell Assig...	Window	Default	All unassigned
Frame Assignments			
Default Frame Ass...	Default Frame	Location	*NONE
Mullion Assignments			
Default Mullion As...	ButtGlaze	Default	All unassigned

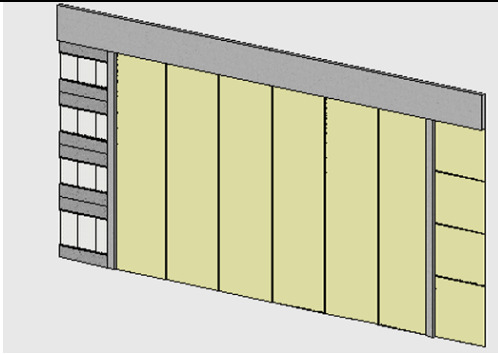

OK back to the drawing and your curtain wall should now have a left side completed with butt jointed glass and stucco panels

See if you can do the right side by yourself, the screen caps are provided here if you need them.

	<table border="1"> <thead> <tr> <th>Name</th> <th>Element</th> <th>Type</th> <th>Used In</th> </tr> </thead> <tbody> <tr> <td colspan="4">Division Assignment</td> </tr> <tr> <td>rightSide</td> <td>FloorToFloor</td> <td>Grid</td> <td>This grid division</td> </tr> <tr> <td colspan="4">Cell Assignments</td> </tr> <tr> <td>floorRight</td> <td>*Nested Grid*</td> <td>Default</td> <td>All unassigned</td> </tr> <tr> <td colspan="4">Frame Assignments</td> </tr> <tr> <td>Default Frame Ass...</td> <td>Default Frame</td> <td>Location</td> <td>*NONE*</td> </tr> <tr> <td colspan="4">Mullion Assignments</td> </tr> <tr> <td>Default Mullion As...</td> <td>StuccoJoint</td> <td>Default</td> <td>All unassigned</td> </tr> </tbody> </table>	Name	Element	Type	Used In	Division Assignment				rightSide	FloorToFloor	Grid	This grid division	Cell Assignments				floorRight	*Nested Grid*	Default	All unassigned	Frame Assignments				Default Frame Ass...	Default Frame	Location	*NONE*	Mullion Assignments				Default Mullion As...	StuccoJoint	Default	All unassigned								
Name	Element	Type	Used In																																										
Division Assignment																																													
rightSide	FloorToFloor	Grid	This grid division																																										
Cell Assignments																																													
floorRight	*Nested Grid*	Default	All unassigned																																										
Frame Assignments																																													
Default Frame Ass...	Default Frame	Location	*NONE*																																										
Mullion Assignments																																													
Default Mullion As...	StuccoJoint	Default	All unassigned																																										
	<table border="1"> <thead> <tr> <th>Name</th> <th>Element</th> <th>Type</th> <th>Used In</th> </tr> </thead> <tbody> <tr> <td colspan="4">Division Assignment</td> </tr> <tr> <td>floorRight</td> <td>OneFloorDivision</td> <td>Grid</td> <td>This grid division</td> </tr> <tr> <td colspan="4">Cell Assignments</td> </tr> <tr> <td>Default Cell Assig...</td> <td>Default Infill</td> <td>Default</td> <td>All unassigned</td> </tr> <tr> <td>New Cell Assignment</td> <td>StuccoInfill</td> <td>Location</td> <td>Bottom, Top</td> </tr> <tr> <td>windowRight</td> <td>*Nested Grid*</td> <td>Location</td> <td>Middle</td> </tr> <tr> <td colspan="4">Frame Assignments</td> </tr> <tr> <td>Default Frame Ass...</td> <td>Default Frame</td> <td>Location</td> <td>*NONE*</td> </tr> <tr> <td colspan="4">Mullion Assignments</td> </tr> <tr> <td>Default Mullion As...</td> <td>mullion</td> <td>Default</td> <td>All unassigned</td> </tr> </tbody> </table>	Name	Element	Type	Used In	Division Assignment				floorRight	OneFloorDivision	Grid	This grid division	Cell Assignments				Default Cell Assig...	Default Infill	Default	All unassigned	New Cell Assignment	StuccoInfill	Location	Bottom, Top	windowRight	*Nested Grid*	Location	Middle	Frame Assignments				Default Frame Ass...	Default Frame	Location	*NONE*	Mullion Assignments				Default Mullion As...	mullion	Default	All unassigned
Name	Element	Type	Used In																																										
Division Assignment																																													
floorRight	OneFloorDivision	Grid	This grid division																																										
Cell Assignments																																													
Default Cell Assig...	Default Infill	Default	All unassigned																																										
New Cell Assignment	StuccoInfill	Location	Bottom, Top																																										
windowRight	*Nested Grid*	Location	Middle																																										
Frame Assignments																																													
Default Frame Ass...	Default Frame	Location	*NONE*																																										
Mullion Assignments																																													
Default Mullion As...	mullion	Default	All unassigned																																										
	<table border="1"> <thead> <tr> <th>Name</th> <th>Element</th> <th>Type</th> <th>Used In</th> </tr> </thead> <tbody> <tr> <td colspan="4">Division Assignment</td> </tr> <tr> <td>windowRight</td> <td>WindRight</td> <td>Grid</td> <td>This grid division</td> </tr> <tr> <td colspan="4">Cell Assignments</td> </tr> <tr> <td>Default Cell Assig...</td> <td>Window</td> <td>Default</td> <td>All unassigned</td> </tr> <tr> <td colspan="4">Frame Assignments</td> </tr> <tr> <td>Default Frame Ass...</td> <td>Default Frame</td> <td>Location</td> <td>*NONE*</td> </tr> <tr> <td colspan="4">Mullion Assignments</td> </tr> <tr> <td>Default Mullion As...</td> <td>ButtGlaze</td> <td>Default</td> <td>All unassigned</td> </tr> </tbody> </table>	Name	Element	Type	Used In	Division Assignment				windowRight	WindRight	Grid	This grid division	Cell Assignments				Default Cell Assig...	Window	Default	All unassigned	Frame Assignments				Default Frame Ass...	Default Frame	Location	*NONE*	Mullion Assignments				Default Mullion As...	ButtGlaze	Default	All unassigned								
Name	Element	Type	Used In																																										
Division Assignment																																													
windowRight	WindRight	Grid	This grid division																																										
Cell Assignments																																													
Default Cell Assig...	Window	Default	All unassigned																																										
Frame Assignments																																													
Default Frame Ass...	Default Frame	Location	*NONE*																																										
Mullion Assignments																																													
Default Mullion As...	ButtGlaze	Default	All unassigned																																										

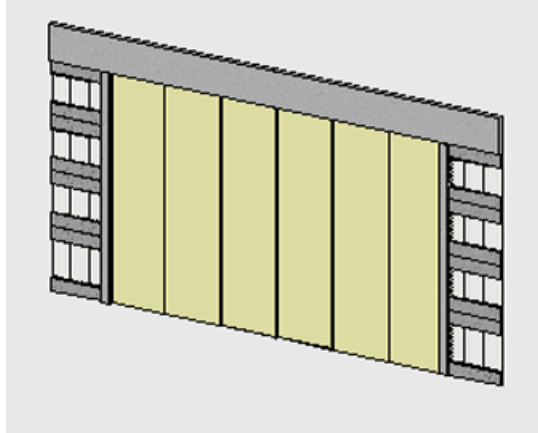

The Middle section looks like this:

- Primary Grid
 - BreakColumnsOut
 - LeftSide
 - OneFloor
 - LeftWindows
 - middle section**
 - 15footBreaks
 - floorMid
 - windowMid
 - LeftSideMdle
 - New Nested Grid
 - New Nested Grid (3)
 - RightSidMdle

Name	Element	Type	Used In
Division Assignment			
middle section	Center15foot	Grid	This grid
Cell Assignments			
15footBreaks	*Nested Grid*	Default	All unass
LeftSideMdle	*Nested Grid*	Location	Start
RightSidMdle	*Nested Grid*	Location	End
Frame Assignments			
Default Frame Ass...	Default Frame	Location	*NONE*
Mullion Assignments			
Default Mullion As...	mullion	Default	All unass

- Primary Grid
 - BreakColumnsOut
 - LeftSide
 - OneFloor
 - LeftWindows
 - middle section
 - 15footBreaks**
 - floorMid
 - windowMid
 - LeftSideMdle
 - New Nested Grid

Name	Element	Type
Division Assignment		
15footBreaks	FloorToFloor	Grid
Cell Assignments		
floorMid	*Nested Grid*	Default
Frame Assignments		
Default Frame Ass...	Default Frame	Location
Mullion Assignments		
Default Mullion As...	StuccoJoint	Default

Name	Element	Type	Used In
Division Assignment			
floorMid	OneFloorDivision	Grid	This grid division
Cell Assignments			
Default Cell Assig...	Default Infill	Default	All unassigned ce
New Cell Assignment	StuccoInfill	Location	Bottom, Top
windowMid	*Nested Grid*	Location	Middle
Frame Assignments			
Default Frame Ass...	Default Frame	Location	*NONE*
Mullion Assignments			
Default Mullion As...	StuccoReveal	Default	All unassigned m

Name	Element	Type	Used In
Division Assignment			
windowMid	WindCenter	Grid	This grid div
Cell Assignments			
Default Cell Assig...	Window	Default	All unassign
Frame Assignments			
Default Frame Ass...	Default Frame	Location	*NONE*
Mullion Assignments			
Default Mullion As...	mullion	Default	All unassign

In order to make the glass on the inside edge of the column auto adjust, the start and ends of this main middle grid (middle section) are defined differently

Name	Element	Type	Used In
Division Assignment			
LeftSideMdle	FloorToFloor	Grid	T
Cell Assignments			
New Nested Grid	*Nested Grid*	Default	A
Frame Assignments			
Default Frame Ass...	Default Frame	Location	*
Mullion Assignments			
Default Mullion As...	StuccoJoint	Default	A

The right side of this mid section is defined exactly the same with the exception of the division assignment at the lowest level is WindLeft. Why WindLeft? Because this strip of curtain wall is to the left of the column where I want the glass to auto adjust itself.

End exercise

The end style created by this exercise is will be available in the dataset provided for this class downloadable either from Autodesk University's web site

www.autodesk.com/auonline.

Or my own site

www.daviddriver.com